



TANKS & SLURRY TECHNOLOGY  
EDITION 2023



GB

# A TRADITION FOR INNOVATION

For decades now, the name Fliegl has stood for quality, innovative action and practical solutions in the world of agriculture. As a result, Fliegl has established itself as Europe's leading manufacturer in the field of agricultural trailers, for example. Be it tippers, original push-off trailers, slurry technology or harvest logistics:

**FLIEGL WILL ALWAYS SUPPLY THE PERFECT TRANSPORT CONCEPT FOR YOUR NEEDS.**





## CONTENTS

<b>Vacuum tank   pump tank   high-pressure tank</b> . . . . .	<b>5-19</b>
Vacuum tank . . . . .	6-11
Pump tank . . . . .	12-17
High-pressure tank. . . . .	18-19
<b>Fliegl Line</b> . . . . .	<b>21-51</b>
Jumbo Line . . . . .	24-25
Jumbo Turbo Line. . . . .	26-27
Jumbo Line Plus . . . . .	28-29
MAXX Line. . . . .	30-35
MAXX Line Plus. . . . .	36-37
DUO Line Plus. . . . .	38-39
ALPHA Line . . . . .	40-45
POLY Line tank trailer. . . . .	46-47
BIG FOOT. . . . .	48-49
TWIST Line pump tank. . . . .	50-51
PROFI Line vacuum tank . . . . .	52-53
Individual tanks and tank bodies . . . . .	54-55
<b>Transport tanks</b> . . . . .	<b>57-65</b>
ROAD X Poly Line . . . . .	58-59
ROAD X Line . . . . .	60-61
STF 30,000 three-axle TRUCK Line . . . . .	62-65
Slurry couplings . . . . .	66-67
<b>Spreading and feed systems</b> . . . . .	<b>69-91</b>
Fliegl screw distributor. . . . .	70
Fliegl FlexFlow. . . . .	71
»Skate« trailing shoe spreader. . . . .	72-83
»Snake« trailing shoe spreader . . . . .	84-85
»Garant« drag hose spreader. . . . .	86
»Vario-Disc« slurry injector . . . . .	87
»Maulwurf« compact disc harrow . . . . .	88
»GUG Profi« slurry cultivator. . . . .	89
Other spreading systems. . . . .	90-91
<b>ISOBUS applications</b> . . . . .	<b>93-101</b>
Fliegl Slurry Tanker. . . . .	94-95
Precision: Fliegl Flow Control. . . . .	96-97
Manure Sensing . . . . .	98-99
Fliegl Nutrient Measure Station . . . . .	100-101





VACUUM TANK | PUMP TANK | HIGH-PRESSURE TANK



# VFW vacuum tank

Capacity: 3000 l to 30,000 l

Ideal for powerful slurry discharge



COMPRESSORS AVAILABLE WITH D

- + Impervious to high foreign body content
- + Compatible with any Fliegl slurry spreader
- + Suitable for virtually any substrate as well as for water



Battioni MEC II 11,000 I  
Heat-resistant



Battioni Ballast 16,000 I  
Heat-resistant

## DIFFERENT POWER LEVELS \*

\* The images merely show examples from our range

# Equipment for vacuum tanks



- 1. Overpressure valve 0.5 bar
- 2. Overpressure/vacuum valve
- 3. Preparation for filling dome
- 4. Additional siphon, up to 8600 l
- 5. Foam separator, from 10,600 l
- 6. Suction nozzle, left or right, for easy suction, incl. docking station
- 7. Siphon
- 8. Hydraulic double-flanged valve

- 9. Hydraulic drawbar suspension (standard on many tank lines)
- 10. Hydraulic control block
- 11. Fill level indicator with float ball
- 12. Plexiglas fill level indicator
- 13. Hydraulic filling dome (400 mm or 600 mm)
- 14. Mechanical filling dome  $\varnothing$  400 mm

- 15. Hydraulic compressor changeover
- 16. Turbo filler possible on left or right side. Opening facility provides optimum access
- 17. Hydraulic internal agitator with paddle screw
- 18. Air agitator



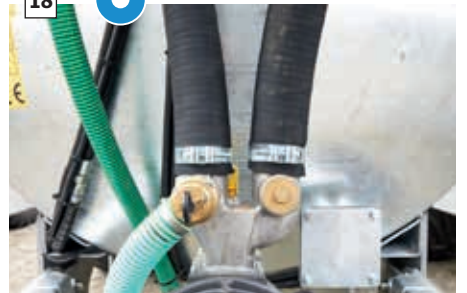
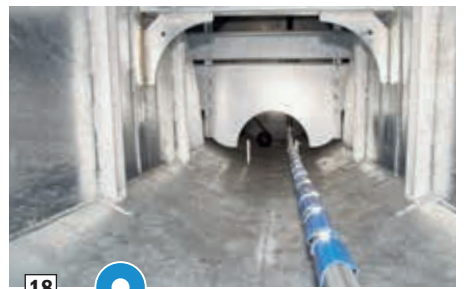
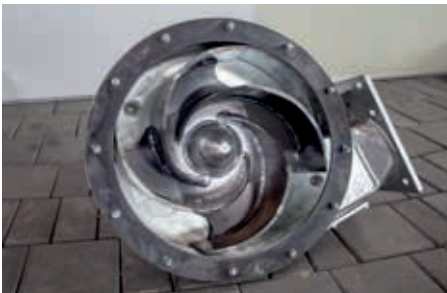
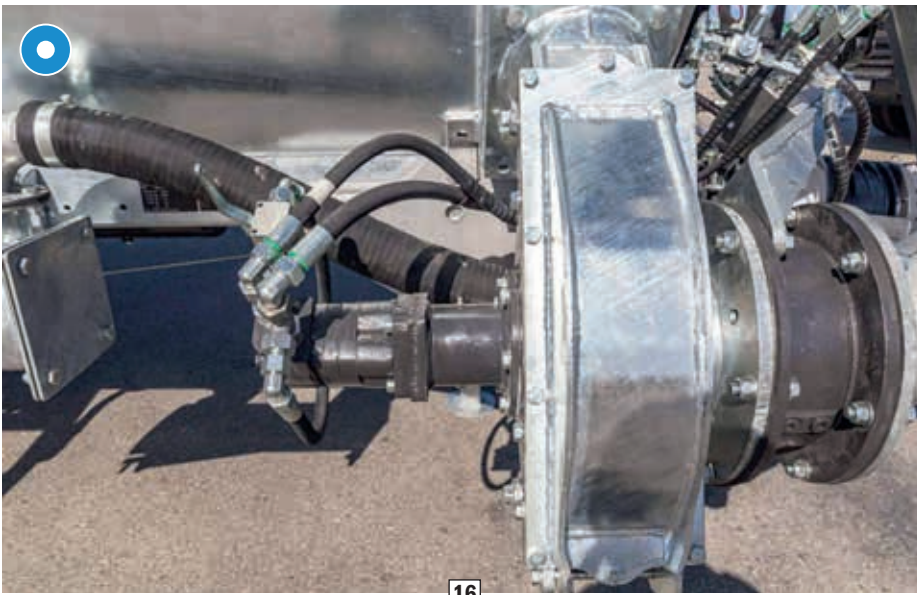

 Standard equipment  Optional



- 19. Green Line version: container painted black and rims painted green
- 20. Discharge accelerator with or without shredding cutter
- 21. Digital tank counter
- 22. Dummy flange, front left, right and rear
- 23. Manway with hydr. discharge valve
- 24. Silencer with oil separator (standard on many tank lines)
- 25. Ladder
- 26. LED working light
- 27. LED lights
- 28. Four-point hydraulics (depending on tank line and size)

- 29. Docking station for elevated tank
- 30. Control panel with joystick control for »Elefant« suction arm. Proportional operation possible (only available for specific tank lines)
- 31. Grease block



Standard equipment
  Optional



PERFECT TECHNOLOGY FOR

# PFW pump tank

Capacity: 6200 l to 27,500 l



+ High suction and spreading performance

+ Low noise emissions

+ Compatible with any Fliegl slurry spreader

+ Linear flow rate during the spreading process with a constant PTO speed

HIGH-PERFORMANCE SUCTION AND SPREADING

# Equipment for pump tanks



- 1. Suction tube with sight glass and foreign body separator
- 2. Pump case with sight glass and foreign body separator
- 3. Clear to see through sight glass: slurry flow and foreign body separator
- 4. Control panel for tank + spreader, depending on configuration
- 5. Hydraulic control block
- 6. Pneumatic pump changeover with knife gate valve
- 7. Hydraulic pump changeover with knife gate valve
- 8. Fill level indicator
- 9. Ladder
- 10. Armatec eccentric screw pump
- 11. Wangen eccentric screw pump
- 12. Vogelsang rotary piston pump for Alpha Line, Big Foot, TWIST Line and Poly Line tanks

## Eccentric screw pump, 4000, 6000 or 7500 l

The eccentric screw pump ensures a pulsation-free flow. The auger-type rotor easily conveys even the most viscous slurry with a high flow rate and high pressure, meaning that even deep slurry pits are no problem for this pump. A 3-way gate valve is used to switch between filling or emptying the tank and to initiate internal stirring.

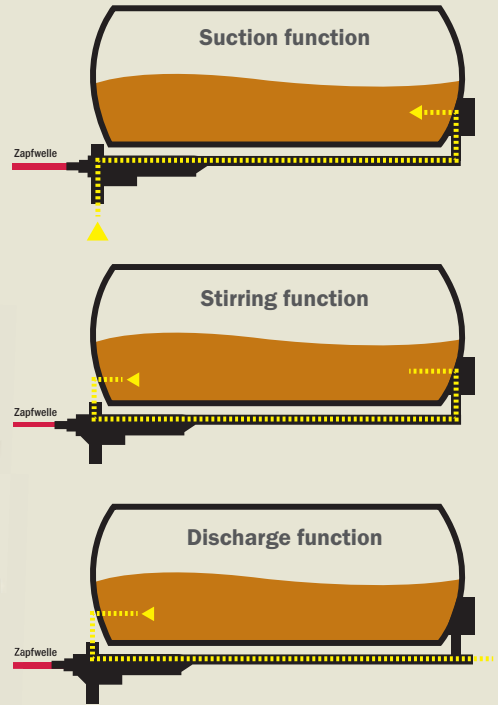
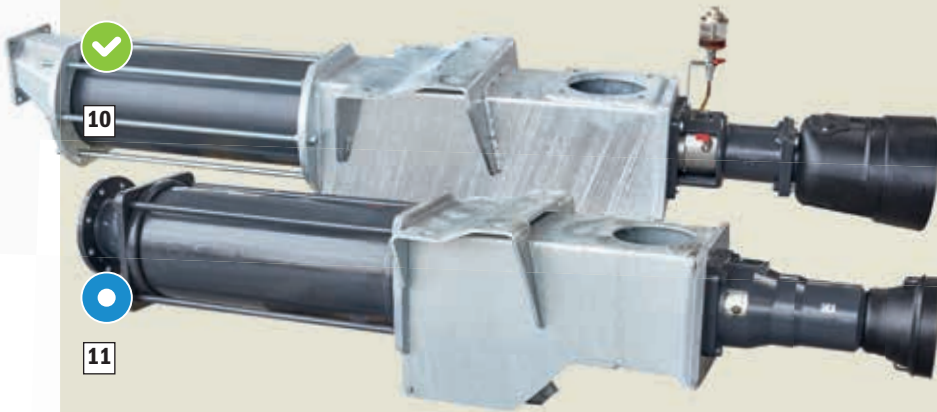

Rotary piston pump

Image credit: Vogelsang GmbH & Co. KG, 49632 Essen/Oldb., Germany



13. Plexiglas fill level indicator

14. Conical three-way valve

15. Tank counter

16. Hydraulic drawbar suspension (standard on many tank lines)

17. Suction nozzle, left or right, for easy suction, incl. docking station

18. Hydraulic push cover

19. Preparation for push cover

20. Manway

21. Docking station for elevated tank

22. Green Line version: container painted black and rims painted green

23. Four-point hydraulics (depending on tank line and size)

24. LED working light

25. LED lights (standard on many tank lines)

26. Control panel with joystick control for »Elefant« suction arm. Proportional operation possible (only available for specific tank lines)

27. Grease block

28. Shredding cutter during suction – hydr. powered (only available for Alpha and Poly Line tanks with eccentric screw pumps)

29. Reduction gear for eccentric screw pump







✔ Standard equipment
 ● Optional

# HFW high pressure tank

Capacity: 5000 l to 27,500 l

The ideal solution for farms with external filling

+ High flow rates

+ Low maintenance with long service life

+ Impervious to foreign objects



Push cover for external filling

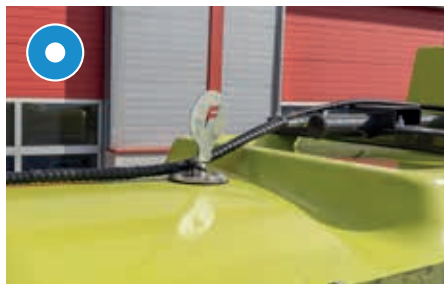

Fill level indicator, top

✓ Standard equipment    ● Optional





Sprinkler nozzle

### TANK SIZES FOR HIGH-PRESSURE TANKS

Individual	Poly Line	Jumbo Line Plus	Maxx Line Plus
5000	6000	14000	14000
6200	9000	16000	16000
7500	11000	18000	18000
8600	12500		
10600	14000		
12000	15500		
14000	18500		
16000			
18000			
20000			
22000			
25000			
27500			



Elba centrifugal pump from Battioni, 3500 or 6500 l/min.



Internal view



Purge line incl. three-valve for optimum stirring function





FLIEGL LINE  
TANK SERIES WITH IMPRESSIVE EQUIPMENT LEVELS



# FLIEGL LINE

## TANKS WITH IMPRESSIVE



### JUMBO Line

Vacuum tanks with a capacity of 3000 l to 10,600 l in single-axle design

**Ideal for smaller farms working on steep inclines**



### JUMBO TURBO Line

Vacuum tanks with a capacity of 3000 l to 8600 l in single-axle design

**Optimum solution for steep areas thanks to Garda Pump in combination with optional sprinkler nozzle**



### JUMBO Line Plus

Pump/Vacuum tanks with a capacity of 14,000 l to 18,000 l in tandem design

**Variable adjustment of drawbar load – perfect for operation on inclines**



### MAXX Line

Pump/Vacuum tanks in single-axle, tandem and tridem design with a capacity of 5000 l to 25,000 l

**Robust construction with low centre of gravity and reliable technology**



### MAXX Line Plus

Pump/Vacuum tanks with a capacity of 12,000 l to 18,000 l in tandem design

**The perfect all-rounder with impressive basic equipment and 750/60 R 30.5 tyres as standard**



### DUO Line Plus

Integrated two-chamber system

**Perfect for spreading on very hilly terrain**

# EQUIPMENT LEVELS



## ALPHA Line

Pump/Vacuum tanks in single-axle, tandem and tridem design with a capacity of 10,600 l to 27,500 l

For professional and intensive use with a range of sophisticated additional equipment



## POLY Line

Pump tank from 9000 l to 18,500 l  
High-pressure tank from 6000 l to 18,500 l

GRP container made in Germany – robust frame construction – low centre of gravity



## BIG FOOT

Pump/Vacuum tanks with a capacity of 16,000 l and 18,000 l

Extremely large tyres with dimensions from 800/60 R 34 for sustainable soil protection



## TWIST Line

Pump tank with a capacity of 13,000 l

Slurry discharge in crab steering mode thanks to centre axle steering for maximum agility and soil protection



## PROFI Line

Vacuum tank with a capacity of 20,000 l and 27,500 l

A gigantic tank with maximum suction performance thanks to the flexible, high-performance suction boom



## Individual tanks

Many possibilities with a wide range of equipment options

# JUMBO Line

Vacuum tanks with a capacity of 3000 l to 10,600 l in single-axle design

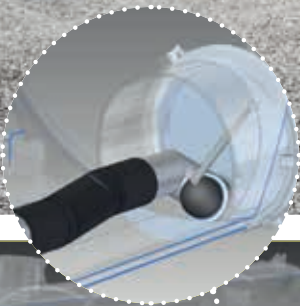

Downhill emptying



Cranked axle on 5000 to 8600 l models  
Low centre of gravity ensures optimum handling on slopes



Standard equipment



Optional





VFW

Jumbo Line	With tyres	Total height in mm without trailing shoe spreader	Total height in mm with trailing shoe spreader	Container length (shell) in mm	Container Ø in mm
<b>3000</b>	15.0/55-17 10 PR	approx. 2310 +/-30	Not possible	3000	1100
<b>4000</b>	15.0/55-17 10 PR	approx. 2440 +/-30	Not possible	3000	1250
<b>5000</b>	710/45 R 26.5	approx. 2620 +/-30	approx. 3280 +/-30	3000	1400
<b>6200</b>	710/45 R 26.5	approx. 2620 +/-30	approx. 3280 +/-30	4000	1400
<b>7500</b>	750/45 R 26.5	approx. 2790 +/-30	approx. 3280 +/-30	4000	1500
<b>8600</b>	750/60 R 30.5	approx. 2940 +/-30	approx. 3280 +/-30	4000	1600
<b>10600</b>	800/65 R 32	approx. 3040 +/-30	approx. 3280 +/-30	5000	1600

# JUMBO TURBO Line

Vacuum tanks with a capacity  
of 3000 l to 8600 l in single-axle design

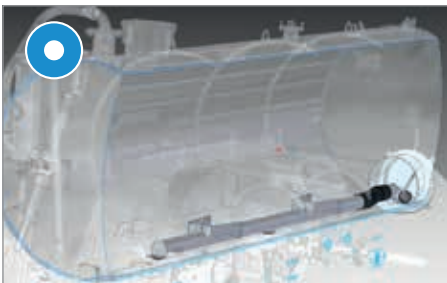

Downhill emptying



Cranked axle on 5000 to 8600 l models  
Low centre of gravity ensures optimum handling on slopes

GARDA pump: combination of centrifugal pump and compressor

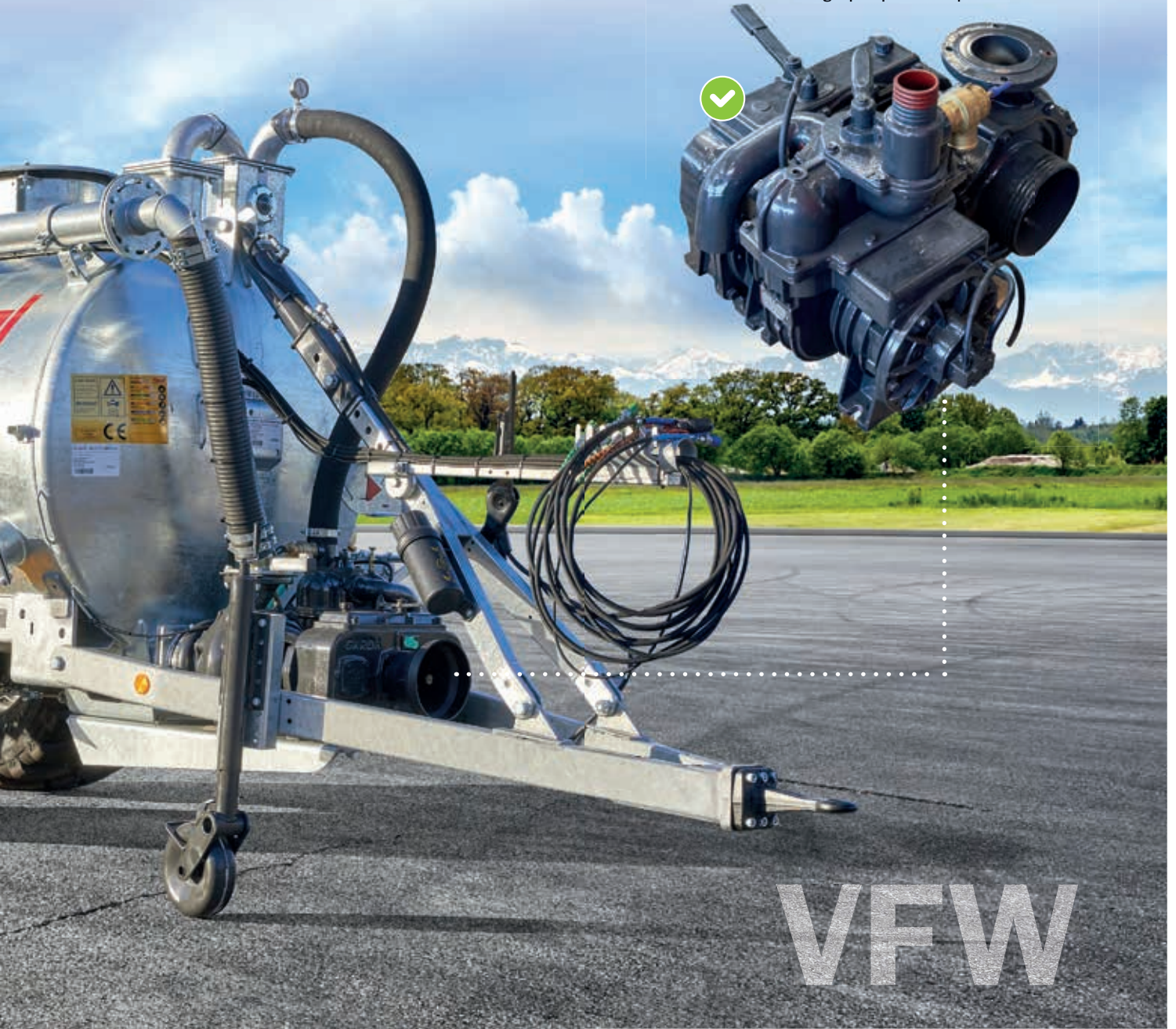

VFW

Jumbo Turbo Line	With tyres	Total height in mm without trailing shoe spreader	Total height in mm with trailing shoe spreader	Container length (shell) in mm	Container Ø in mm
3000	15.0/55-17 10 PR	approx. 2630 +/-30	Not possible	3000	1100
4000	15.0/55-17 10 PR	approx. 2840 +/-30	Not possible	3000	1250
5000	710/45 R 26.5	approx. 2920 +/-30	approx. 3280 +/-30	3000	1400
6200	710/45 R 26.5	approx. 2920 +/-30	approx. 3280 +/-30	4000	1400
7500	750/45 R 26.5	approx. 3050 +/-30	approx. 3280 +/-30	4000	1500
8600	750/60 R 30.5	approx. 3260 +/-30	approx. 3280 +/-30	4000	1600

✔ Standard equipment    
 ○ Optional

# JUMBO Line Plus

Pump/Vacuum tanks with a capacity of 14,000 l to 18,000 l in tandem design



Steering axle from **BPW 410 x 180**

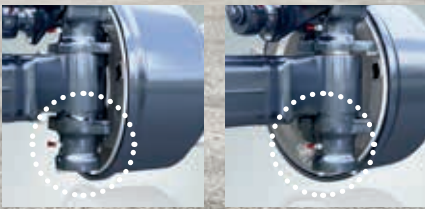

Steered

Straight-ahead travel



Hydraulic or electronic forced steering



**Wheel arch and tyres**  
**750/60-R30.5" tyres**  
Optional: 750/60-R30.5" tyres at rear,  
850/50-R30.5 at front



Ball head K80

**PFW Jumbo Line Plus tandem**

	With tyres	Total height in mm with trailing shoe spreader	Container length (shell) in mm	Container Ø in mm
14000	750/60 R 30.5	approx. 3540 +/-30	6000	1700
16000	750/60 R 30.5	approx. 3540 +/-30	6000	1800
18000	750/60 R 30.5	approx. 3620 +/-30	6000	1900

**VFW Jumbo Line Plus tandem**

	With tyres	Total height in mm with trailing shoe spreader	Container length (shell) in mm	Container Ø in mm
14000	750/60 R 30.5	approx. 3430 +/-30	6000	1700
16000	750/60 R 30.5	approx. 3550 +/-30	6000	1800
18000	750/60 R 30.5	approx. 3650 +/-30	6000	1900

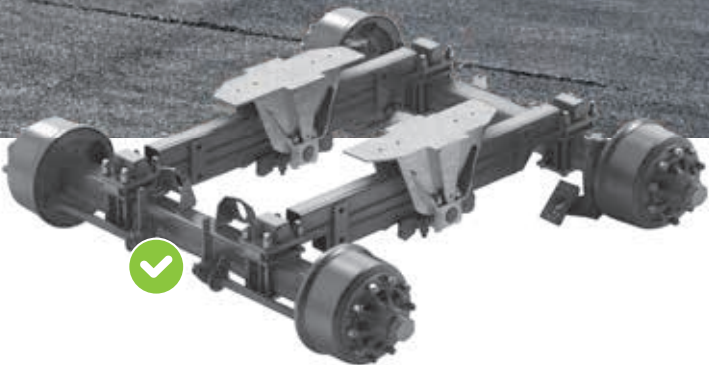

Boogie SB floating assembly

**Hydraulically adjustable axle assembly**



Optimum adaptation of drawbar load:  
infinite hydraulic adjustment,  
incl. for attachment of slurry  
spreaders, e.g. trailing shoe  
spreader



Axles moved back for field  
operation  
Higher drawbar load = im-  
proved tractor traction



Axles moved forward for driving  
on road  
Lower drawbar load = better  
ride comfort and less wear



Hydraulic axle adjustment

✓ Standard equipment    ● Optional

# MAXX Line single-axe

Pump/Vacuum tanks with a capacity of 5000 l to 10,600 l

# PFW



Tyres: up to 800/65 R32

PFW Maxx Line single-axe	With tyres	Total height in mm with trailing shoe spreader	Container length (shell) in mm	Container Ø in mm
6200	750/45 R 26.5	approx. 3280 +/-30	4000	1400
7500	750/45 R 26.5	approx. 3280 +/-30	4000	1500
8600	750/60 R 30.5	approx. 3280 +/-30	4000	1600
10600	800/65 R 32	approx. 3280 +/-30	5000	1600

# VFW



Tyres: up to 750/45 R26.5

VFW Maxx Line single-axle	With tyres	Total height in mm with trailing shoe spreader	Container length (shell) in mm	Container Ø in mm
5000	710/45 R 26.5	approx. 3280 +/-30	3000	1400
6200	710/45 R 26.5	approx. 3280 +/-30	4000	1400
7500	750/45 R 26.5	approx. 3280 +/-30	4000	1500
8600	750/45 R 26.5	approx. 3280 +/-30	4000	1600
10600	750/45 R 26.5	approx. 3280 +/-30	5000	1600



Standard equipment



Optional

# MAXX Line tandem

Pump/Vacuum tanks with a capacity of 8600 l to 18,000 l



Up to 26.5" tyres possible



PFW

PFW Maxx Line tandem	With tyres	Total height in mm with trailing shoe spreader	Container length (shell) in mm	Container Ø in mm
8600	710/45 R 22.5	approx. 3280 +/-30	4000	1600
10600	750/45 R 26.5	approx. 3280 +/-30	5000	1600
12000	750/45 R 26.5	approx. 3300 +/-30	5000	1700
14000	750/45 R 26.5	approx. 3370 +/-30	5500	1800
16000	750/45 R 26.5	approx. 3420 +/-30	6000	1800
18000	750/45 R 26.5	approx. 3460 +/-30	6000	1900



Standard equipment



Optional





»TITAN« axle assembly  
up to MAXX Line 14,000 l



»Gigant« axle assembly  
for MAXX Line 16,000 l

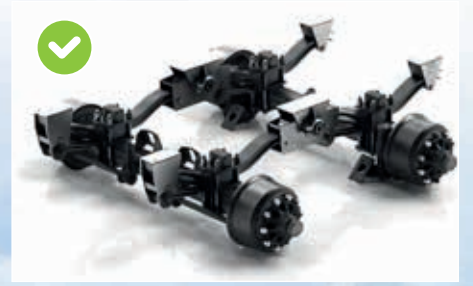

»Gigant Plus« axle assembly  
from MAXX Line 18,000 l



VFW

VFW Maxx Line tandem	With tyres	Total height in mm with trailing shoe spreader	Container length (shell) in mm	Container Ø in mm
8600	710/45 R 22.5	approx. 3280 +/-30	4000	1600
10600	750/45 R 26.5	approx. 3280 +/-30	5000	1600
12000	750/45 R 26.5	approx. 3280 +/-30	5000	1700
14000	750/45 R 26.5	approx. 3400 +/-30	5500	1800
16000	750/45 R 26.5	approx. 3400 +/-30	6000	1800
18000	750/45 R 26.5	approx. 3470 +/-30	6000	1900

# MAXX Line tridem

Pump/Vacuum tanks with a capacity of 20,000 l and 25,000 l



PFW MAXX Line tridem	With tyres	Total height in mm with trailing shoe spreader	Container length (shell) in mm	Container Ø in mm
20000	750/45 R 26.5	approx. 3460 +/-30	7000	1900
25000	750/45 R 26.5	approx. 3560 +/-30	7450	2000
VFW MAXX Line tridem				
20000	750/45 R 26.5	approx. 3470 +/-30	7000	1900
25000	750/45 R 26.5	approx. 3570 +/-30	7450	2000



Only for vacuum tank: turbo filler with side-mounted quick coupler

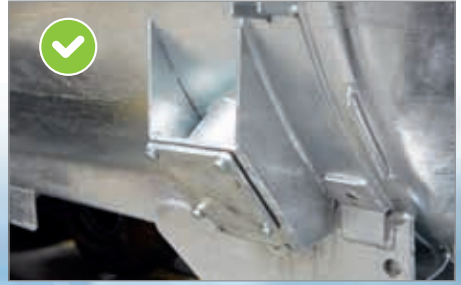

Only for vacuum tank: With dummy flange as standard – front right, left and rear



»Gigant Plus« axle assembly



Ball head K80



Up to 26.5" tyres possible

✔ Standard equipment  
 ● Optional

# MAXX Line Plus

Pump/Vacuum tanks with a capacity of 12,000 l to 18,000 l in tandem design



**Wheel arch and tyres**  
**750/60-R30.5"**  
Optional: 750/60-R30.5" tyres at rear  
850/50-R30.5" at front

PFW



»Gigant« axle assembly for MAXX Line Plus 12,000 l and 14,000 l

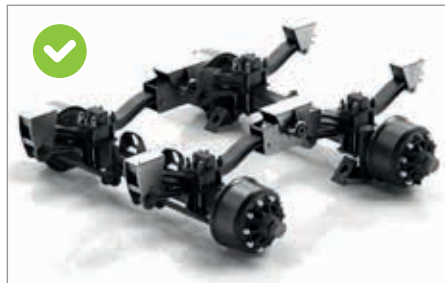

»Gigant Plus« axle assembly for MAXX Line Plus 16,000 l and 18,000 l



Hydraulic drawbar suspension



Standard equipment



Optional

VFW Maxx Line Plus tandem	With tyres	Total height in mm with trailing shoe spreader	Container length (shell) in mm	Container Ø in mm
12000	750/60 R 30.5	approx. 3490 +/-30	5500	1700
14000	750/60 R 30.5	approx. 3490 +/-30	6000	1700
16000	750/60 R 30.5	approx. 3510 +/-30	6000	1800
18000	750/60 R 30.5	approx. 3620 +/-30	6000	1900
20000	750/60 R 30.5	approx. 3720 +/-30	6000	2000

**PFW Maxx Line Plus tandem**

12000	750/60 R 30.5	approx. 3590 +/-30	5500	1700
14000	750/60 R 30.5	approx. 3590 +/-30	6000	1700
16000	750/60 R 30.5	approx. 3520 +/-30	6000	1800
18000	750/60 R 30.5	approx. 3620 +/-30	6000	1900
20000	750/60 R 30.5	approx. 3720 +/-30	6000	2000



VFW



Steering axle from BPW



Hydraulic or electronic forced steering



Ball head K80



For vacuum tank: turbo filler positioned centrally under tank – for suction on either side

# DUO Line Plus

Pump tanks with two-chamber system



Function

Vent valve for uniform filling of the two chambers



Residual emptying takes place once the slurry volume in the rear chamber has dropped to a level that allows air to enter the front chamber via the separating wall.

**The Fliegl two-chamber system proves particularly advantageous on very hilly terrain:**

During discharge, the rear chamber is emptied first. This ensures an ideal drawbar load at the rear of the tractor when travelling uphill.



PFW DUO Line Plus tandem	With tyres	Total height in mm with trailing shoe spreader	Container length (shell) in mm	Container Ø in mm
12000	750/60 R 30.5	approx. 3590 +/-30	5500	1700
14000	750/60 R 30.5	approx. 3590 +/-30	6000	1700
16000	750/60 R 30.5	approx. 3520 +/-30	6000	1800
18000	750/60 R 30.5	approx. 3620 +/-30	6000	1900

# ALPHA Line single-axle

Pump/Vacuum tanks with a capacity of 10,600 l to 14,000 l



PFW

Special drawbar design with optimum pull point ✓



Only for pump tanks: 8" suction arm, 5 m length



Tyres for spreading on maize crops



Tyre pressure control system



VFW Alpha Line single-axle	With tyres	Total height in mm with trailing shoe spreader	Container length (shell) in mm	Container Ø in mm
10600	900/60 R 32	approx. 3390 +/-30	5000	1600
12000	900/60 R 32	approx. 3400 +/-30	5000	1700
14000	900/60 R 32	approx. 3560 +/-30	5000	1900







ALL ISOBUS APPLICATIONS AVAILABLE

VFW

For vacuum tank: turbo filler positioned centrally under tank – for suction on either side

PFW Alpha Line single-axle	With tyres	Total height in mm with trailing shoe spreader	Container length (shell) in mm	Container Ø in mm
10600	900/60 R 32	approx. 3380 +/-30	5000	1600
12000	900/60 R 32	approx. 3390 +/-30	5000	1700
14000	900/60 R 32	approx. 3560 +/-30	5000	1900

 Standard equipment
  Optional

# ALPHA Line tandem

Pump/Vacuum tanks with a capacity of 14,000 l to 20,000 l



Tyre pressure control system



Individual wheel arches

PFW

PFW Alpha Line tandem	With tyres	Total height in mm with trailing shoe spreader	Container length (shell) in mm	Container Ø in mm
14000	750/60 R 30.5	approx. 3460 +/-30	6500	1700
16000	750/60 R 30.5	approx. 3540 +/-30	6500	1800
18000	750/60 R 30.5	approx. 3650 +/-30	6500	1900
20000	750/60 R 30.5	approx. 3750 +/-30	6500	2000



Only for pump tanks: 8" suction arm, 5 m length



Hydraulic axle suspension



For vacuum tank: turbo filler positioned centrally under tank – for suction on either side

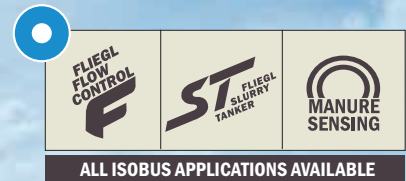

VFW Alpha Line tandem

With tyres

Total height in mm with trailing shoe spreader

Container length (shell) in mm

Container Ø in mm

14000	750/60 R 30.5	approx. 3450 +/-30	6500	1700
16000	750/60 R 30.5	approx. 3560 +/-30	6500	1800
18000	750/60 R 30.5	approx. 3660 +/-30	6500	1900
20000	750/60 R 30.5	approx. 3780 +/-30	6500	2000

✓ Standard equipment    ○ Optional

# ALPHA Line tridem

Pump/Vacuum tanks with a capacity of 23,000 l to 27,500 l

# PFW



Only for pump tanks: 8" suction arm, 5 m length



Hydraulic or electronic forced steering



Individual wheel arches in combination with hydr. suspension

VFW Alpha Line tridem	With tyres	Total height in mm with trailing shoe spreader	Container length (shell) in mm	Container Ø in mm
23000	750/60 R 30.5	approx. 3780 +/-30	7450	2000
25000	750/60 R 30.5	approx. 3880 +/-30	7450	2100
27500	750/60 R 30.5	approx. 3940 +/-30	7450	2150

**PFW Alpha Line tridem**

23000	750/60 R 30.5	approx. 3750 +/-30	7450	2000
25000	750/60 R 30.5	approx. 3850 +/-30	7450	2100
27500	750/60 R 30.5	approx. 3890 +/-30	7450	2150





FLIEGL  
FLOW  
CONTROL



ST  
FLIEGL  
SLURRY  
TANKER



MANURE  
SENSING

ALL ISOBUS APPLICATIONS AVAILABLE

# VFW



Tyre pressure control system



Hydraulic axle suspension



For vacuum tank: turbo filler positioned centrally under tank – for suction on either side

✔ Standard equipment    
 ○ Optional

# POLY Line tank trailer

Pump tank from 9000 l to 18,500 l

High-pressure tank from 6000 l to 18,500 l



Pump tank Poly Line 900 with rotary piston pump



PFW Poly Line	Tyres	Total height in mm with trailing shoe spreader	Container length (shell) in mm
9000 single-axle Individual	750/60 R 30.5	approx. 3410 +/-30	3650
11000 single-axle Individual	850/50 R 30.5	approx. 3280 +/-30	5050
11000 tandem Individual	750/45 R 26.5	approx. 3280 +/-30	5050
12500 tandem Poly Line Plus	750/60 R 30.5	approx. 3380 +/-30	5050
14000 tandem Poly Line Plus	750/60 R 30.5	approx. 3580 +/-30	5050
15500 tandem Poly Line Plus	750/60 R 30.5	approx. 3380 +/-30	6450
18500 tandem Poly Line Plus	750/60 R 30.5	approx. 3580 +/-30	6450



Standard equipment



Optional



Push cover, 600 x 600 mm, pneumatic or hydraulic

+ GRP tank – made in Germany

+ Easy to clean

+ Extremely low centre of gravity

+ Robust frame construction

+ Low net weight

### PolyLine GRP tanks

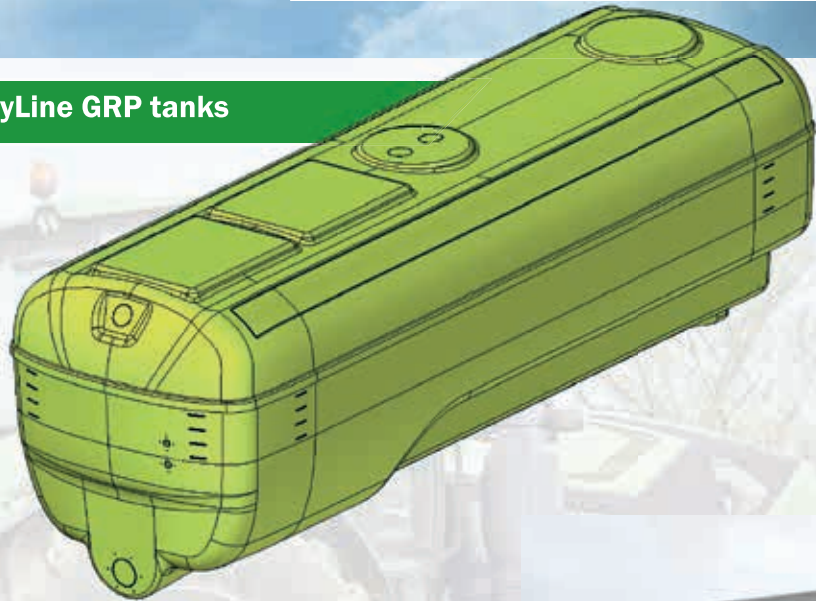

- Special edging on the front and rear face ensures outstanding stability
- The porthole facilitates visual control during filling
- Low centre of gravity
- Perfectly integrated and easily accessible pressure line



Jumbo Gigant Plus tandem assembly for 15,500 l and 18,500 l Poly Line Plus

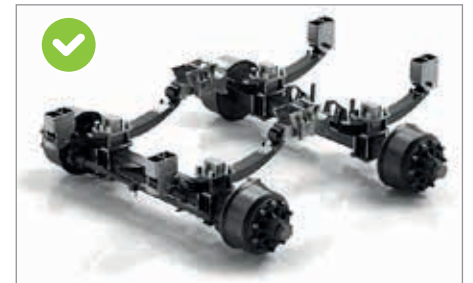

Gigant tandem assembly for 11,000 l, 12,500 l and 14,000 l Poly Line Plus

# »BIG FOOT«

Pump/Vacuum tanks with a capacity of 16,000 l and 18,000 l



OPTIMUM SOIL



800/60 R34 tyres



Hydraulic turbo filler, centrally under tank



Double-sided drawbar suspension

 Standard equipment  Optional





Hydraulically sprung axle assembly

# PROTECTION

<b>PFW BIG FOOT tandem</b>	<b>Tyres</b>	<b>Total height in mm with trailing shoe spreader</b>	<b>Container length (shell) in mm</b>	<b>Container Ø in mm</b>
16000 tandem	800/60 R 34	approx. 3610 +/-30	6500	1800
18000 tandem	800/60 R 34	approx. 3720 +/-30	6500	1900
<b>VFW BIG FOOT tandem</b>				
16000 tandem	800/60 R 34	approx. 3630 +/-30	6500	1800
18000 tandem	800/60 R 34	approx. 3730 +/-30	6500	1900

# »TWIST Line«

Pump tank with a capacity of 13,000 l

Thanks to the central mounting, the axle of the single-axle tank can be rotated by approx. 11 degrees relative to the tank container to enable travel in crab steering mode. As a result, soil compaction is greatly reduced. As soon as the axle turns, the optional three-point hydraulics are swivelled accordingly, thus eliminating the need for an additional pivoting headstock for the attachment.



Scan here to watch video



Three-point hydraulics turn with the axle steering movements



8" suction arm, hydr. swivelling



Double-sided drawbar suspension

 Standard equipment

 Optional

## AGILE AND SOIL-FRIENDLY



900/60 R32 tyres



Centrally mounted axle, hydraulic steering for crab steering mode



Very easy to maintain: mechanically operated rotary piston pump incl. reduction gear

# »PROFI Line«

Vacuum tank with a capacity of 20,000 l and 27,500 l



Transfill suction boom – operated via Joystick control. Proportional operation. Approx. 10 m fully extended. Flexible application thanks to robust slewing ring and three joints. Turbo filler at end of boom for outstanding suction performance.

In combination with the standard Transfill suction boom, the vacuum tanks of the Fliegl PROFI Line deliver unrivalled performance and flexibility during tank filling. The turbo filler at the end of the suction boom works with the compressor to achieve suction rates of up to 8000 litres per minute.



Drip pan for Transfill suction boom with automatic emptying on the field



Air suspension  
Optional: hydraulic suspension



Heat-resistant compressor  
Optional: water-cooled compressor

 Standard equipment
  Optional

# Tank bodies & individual tanks



## TANK SIZES FOR TANK BODIES

10600      12000      14000      16000      18000      20000      22000      25000





**The Fliegl swap system**  
Optional slurry tank bodies  
for swap chassis.



VFW 25000 Individual



VFW 14000 Individual with Garda pump

#### TANK SIZES FOR INDIVIDUAL TANKS

Vacuum tanks	Pump tanks	High-pressure tanks
10600	10600	5000
12000	12000	6200
14000	14000	7500
16000	16000	8600
18000	18000	10600
20000	20000	12000
22000	22000	14000
25000	25000	16000
30000		18000
		20000
		22000
		25000
		27500







## TRANSPORT TANKS



# ROAD X POLY Line

Plastic transport tanks for your tractor

- ✓ • Push cover for external filling
- Hydraulic drawbar suspension
- Air suspension
- 6" transfer arm, length 6 m incl. hopper for storage
- Riser pipe with 8" docking funnel
- Hydraulic forced steering
- Tyres: 445/65-R22.5



TFW Road X Poly Line	With tyres	Total height in mm incl. top docking funnel	Container length
18000 tandem	445/65 R 22.5	approx. 3520 +/-30	5910 mm
20000 tandem	445/65 R 22.5	approx. 3660 +/-30	5910 mm
29000 tridem	445/65 R 22.5	approx. 3950 +/-30	6950 mm



Centrifugal pump  
6500 l/min.

HIGH PERFORMANCE ROBUST TECHNOLOGY HIGH TRANSFER CAPACITY LOW NET WEIGHT



Very easy to maintain: mechanically operated rotary piston pump incl. reduction gear

Special frame construction made from fine-grain steel



Standard equipment



Optional

# ROAD X Line

transport tanks in steel construction for your tractor



- Hydr. filling dome, 600 mm Ø
- Hydraulic drawbar suspension
- Air suspension



- 6" transfer arm, length 6 m incl. hopper for storage
- Riser pipe with 8" docking funnel
- Hydraulic forced steering
- Tyres: 445/65-R22.5 or 560/600-R22.5



Very easy to maintain:  
mechanically operated  
rotary piston pump  
incl. reduction gear



Centrifugal pump for transferring



6" transfer arm / length: 6 m



# TFW with turntable

Capacity: 14,000 l | 16,000 l | 20,000 l







TFW 20,000 three-axle



Pressure line incl. conical three-way valve



-  High performance
-  Robust technology
-  High transfer capacity
-  Low net weight



Road X Line 27,500 tridem

Road X Line	Container length (shell)	Total height with 445/65 R 22.5 tyres incl. top docking with riser pipe
16,000 tandem	6,000 mm	n/a
20,000 tandem	6,000 mm	n/a
25,000 tridem	7,450 mm	3,700 mm
27,500 tridem	7,450 mm	3,750 mm

 Standard equipment  Optional

# STF 30,000 three-axle TRUCK Line

Tank capacity 30,000 l – excellent handling thanks to high-quality chassis components

- + Chassis frame made from high-strength fine-grain steel
- + Net weight from 5900 kg; perm. total weight 35,000 kg (with coupling load of 11,000 kg)
- + Optional alloy rims for 385/65 R22.5 tyre

• Container made from stainless steel, painted



6" suction gate valve at rear of tank, 180° swivel function (in combination with rotary piston pump)



Rear docking funnel at top of tank



SAF axles with disc brake

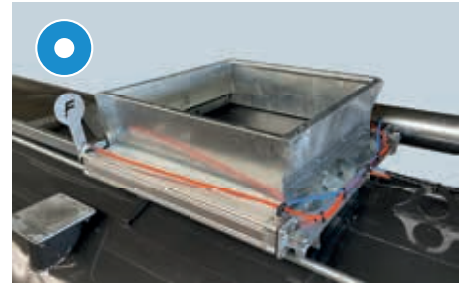

Pneumatic push cover for external filling from above



Scan here to watch video



3 baffle plates



Integrated overpressure system with outlet and negative pressure relief



Storage hopper for transfer arm with overflow protection



Coupling height 1200 to 1300 mm

Air-sprung chassis with first axle for lifting and final axle as steering axle



Standard equipment



Optional



Additional fill level indicator via Plexiglas tube



Powerful rotary piston pump from Vogelsang (model VX 186-260Q) with auxiliary suction function for emptying the slurry hose when reported as full



Storage compartment for suction hose

- + Lower traction force requirement and high payload thanks to low net weight
- + Excellent handling thanks to high-quality chassis components
- + Stainless steel construction ensures long service life

- + High performance for suction and transfer with optional Vogelsang rotary piston pump and transfer arm
- + Optimum stirring action with integrated purge line in combination with rotary piston pump



Operation via external control system (only in combination with rotary piston pump)



Operation via radio remote control





Transfer arm length from 7 m, hydraulic swivel function





# Slurry couplings

All Fliegl tanks use the »Italian system « as standard.

## THE »ITALIAN« SYSTEM

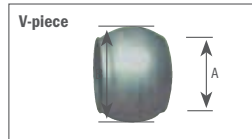
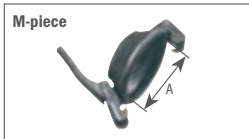

With this system, levers are **welded to the M-piece**. The **V-piece features a ball with a loose clamping ring**. This ring must have a sharp edge where the levers of the M-piece engage. If this edge is rounded, this is known as the »Bazzoli Siegperle« system.

To determine the size of the Italian coupling, you must measure either the outside diameter of the V-piece or the inside diameter of the M-piece. The outside diameter of the V-piece or the inside diameter of the M-piece must be the same for the M-piece and the V-piece. The coupling hose connector is measured on the outside or by the inside hose diameter.

### Sizes of the Italian system

#### M-piece (with O-ring)

Inside dim. A 131 mm = 4"  
 Inside dim. A 151 mm = 5"  
 Inside dim. A 181 mm = 6"  
 Inside dim. A 245 mm = 8"  
 Inside dim. A 301 mm = 10"  
 Inside dim. A 371 mm = 12"

#### V-piece (with loose clamping ring)

Outside dim. B 130 mm / inside dim. A 100 mm = 4"  
 Outside dim. B 150 mm / inside dim. A 120 mm = 5"  
 Outside dim. B 180 mm / inside dim. A 150 mm = 6"  
 Outside dim. B 240 mm / inside dim. A 205 mm = 8"  
 Outside dim. B 300 mm / inside dim. A 254 mm = 10"  
 Outside dim. B 370 mm / inside dim. A 304 mm = 12"

#### Hose sizes

4" = 100 mm  
 5" = 120 mm  
 6" = 150 mm  
 8" = 200 mm  
 10" = 250 mm  
 12" = 300 mm



6" quick coupler



## THE »PERROT« SYSTEM

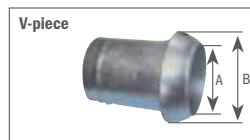
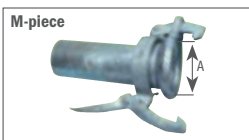

This system features a movable ring on the **M-piece to which the levers are attached**. The **V-piece has a cone** and consists of only one part. To determine the size of the Perrot coupling, you must measure either the outside diameter of the V-piece or the inside diameter of the M-piece. The coupling hose connector is measured on the outside or by the inside hose diameter.

### Sizes of the Perrot system

#### M-piece (with O-ring)

Inside dim. A 150.0 mm = 4"  
 Inside dim. A 171.5 mm = 5"  
 Inside dim. A 203.5 mm = 6"  
 Inside dim. A 288.0 mm = 8"

#### Perrot V-piece

Outside dim. B 155 mm / inside dim. A 108 mm = 4"  
 Outside dim. B 179 mm / inside dim. A 133 mm = 5"  
 Outside dim. B 211 mm / inside dim. A 159 mm = 6"  
 Outside dim. B 313 mm / inside dim. A 216 mm = 8"

#### Hose sizes

4" = 108 mm  
 5" = 133 mm  
 6" = 159 mm  
 8" = 216 mm



Perrot 6" quick coupler







## SPREADING AND FEED SYSTEMS



# Fliegl screw distributor

## Part of all Fliegl spreading systems

### Function

The function of the screw (50 - 60 rpm) is not to distribute slurry, but to convey foreign objects outwards into the trap box. The timing relay is set such that the screw runs outwards for approx. 20 seconds and inwards for 5 seconds.

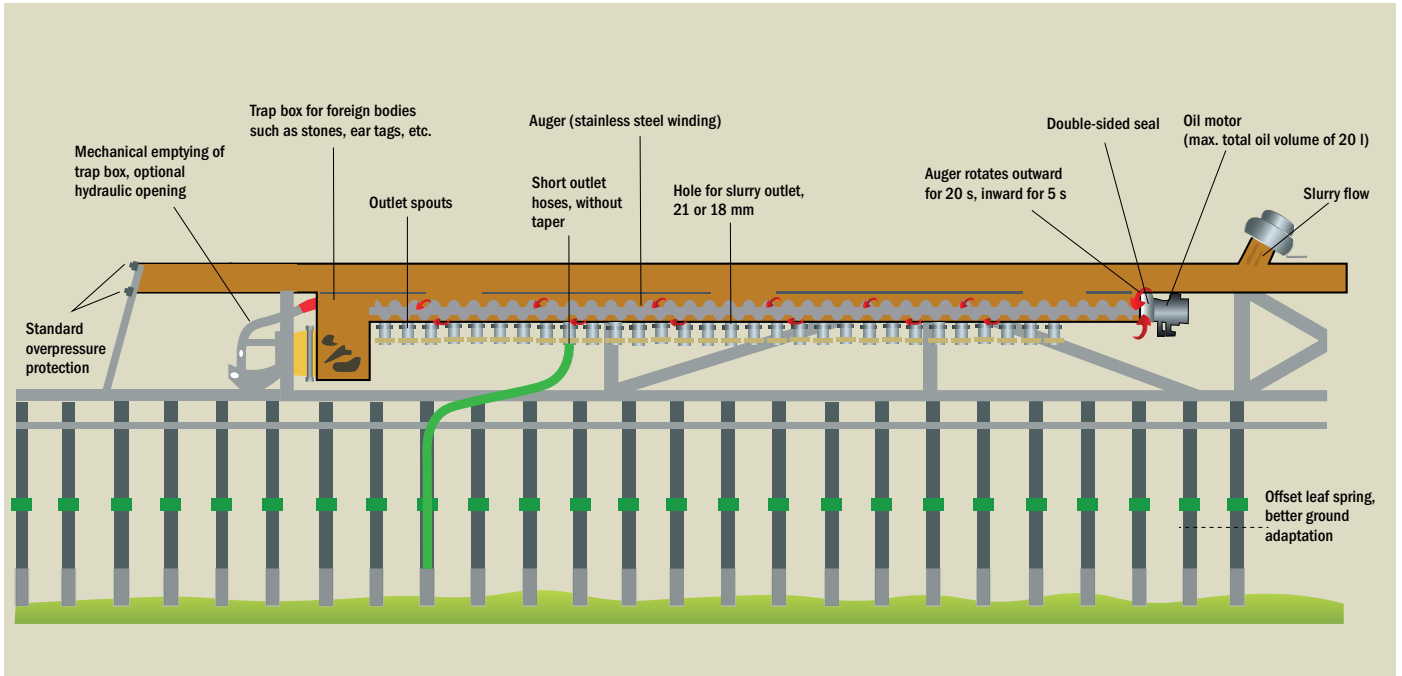

Trap box for foreign objects, emptied mechanically or hydraulically



Foreign objects such as pieces of wood, stones, earmarks etc. are easily removed from the system



Function

**+** Unbeatable foreign object separation without clogging

**+** Uniform longitudinal and transverse distribution – even on inclines

# Optional: Fliegl FlexFlow

The hole size of the discharge openings on the screw troughs can be altered by means of a sliding rail combined with a lever mechanism.

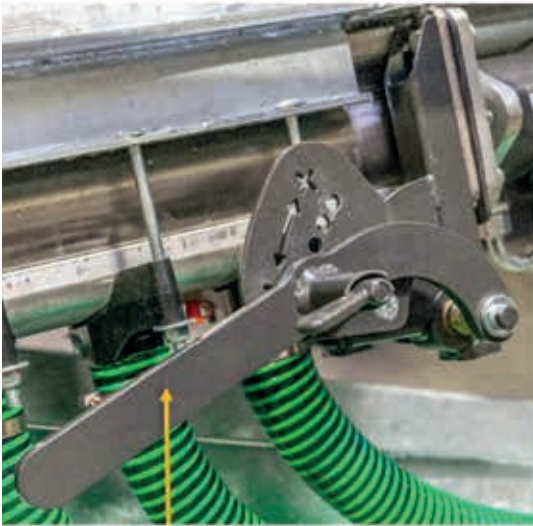

The lever enables mechanical adjustment of the hole size.

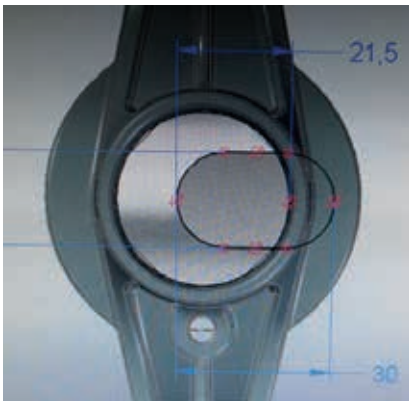
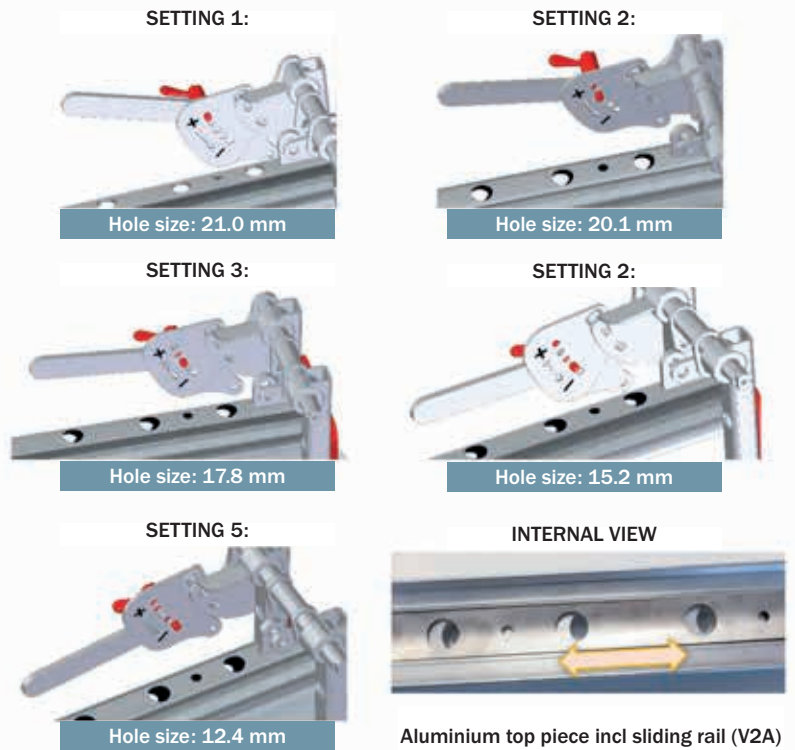

- FlexFlow ensures perfect longitudinal and transverse distribution of any discharge volume.
- FlexFlow allows corresponding adjustments to be made when the flow rate is altered by the pump speed
- FlexFlow enables spreading of very small slurry volumes with above-average nutrient content
- FlexFlow supports flexible selection of the travel speed based on the traction force requirement and ground conditions

# »SKATE« trailing shoe spreader

Ideal for grassland and farmland



		SKATE 60	SKATE 75	SKATE 90	SKATE 120	SKATE 150	SKATE 180	SKATE 180 XL	SKATE 210	SKATE 240
Working width	m	6	7.5	9	12	15	18	18	21	24
Number of outlets		24	30	36	48	60	72	72	84	96
Weight	kg	660	900	1100	1300	1550	1850	2200	2800	3300
Transport width (top/bottom)	mm	2300/ 2600	2300/ 2600	2300/ 2600	2300/ 2600	2300/ 2600	2300/ 2600	2600/ 2990	2600/ 2990	2600/ 2990
Boom ends hydr. folding	m	-	-	-	-	-		18/15	21/15	24/18



# SKATE

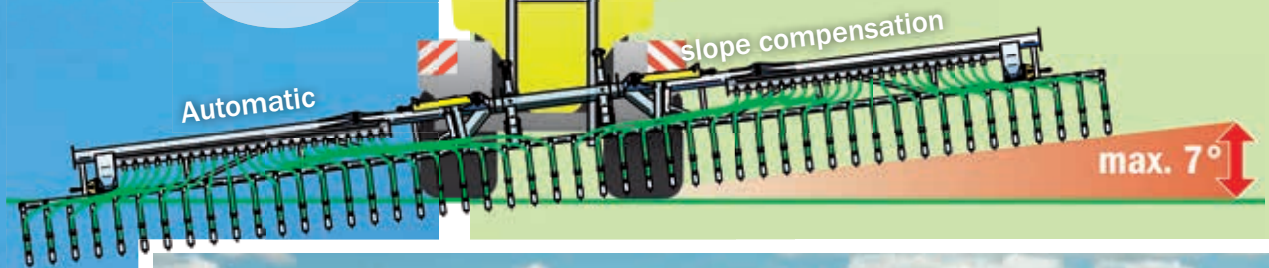

SKATE 210 (21 m working width, reducible to 15 m)



Fliegl SKATE 210 with pendulum frame for better slope compensation (only on SKATE 210/240)

## Working widths from 6 to 24 m

- Solid design combined with low net weight thanks to special frame and spreader construction
- No reduction in drawbar load as trailing shoe spreader makes full contact with the ground
- High coulter pressure of 8 kg per slit shoe
- With automatic slope compensation as standard
- Special inclined swivel joints ensure an extremely narrow transport position and, consequently, excellent all-round visibility
- Very narrow transport width of about 2300 mm at the top
- Automatic drip stop function; spreader is swivelled up by comfort control
- Outstanding slurry distribution, low maintenance and low oil requirement (max. 20 l) thanks to the **Fliegl screw distributor**
- Special folding mechanism avoids kinks in outlet hoses during extension and retraction
- Sprung slit shoes for optimum ground adaptation
- Mechanical or hydraulic boom section control possible
- Mechanical shut-off of individual hose outlets possible
- Simple mounting directly on the tank, even with older models
- Comfort control with automatic folding and headland function as standard
- Operation via tractor control unit (pressure-free return required) or via load sensing
- Control via ISOBUS possible
- Narrow hose spacing of 250 mm is ideal for grassland and farmland

# Fliegl SKATE: Very good results in DLG test

Function and processing quality, handling, operation and maintenance

## DLG Test Report 7167: FLIEGL SKATE 120



**FLIEGL SKATE 120 (12 METER)  
MIT FLIEGL SCHNECKENVERTEILERN**  
✓ Funktion und Arbeitsqualität  
✓ Handhabung, Bedienung  
und Wartung  
DLG-Prüfbericht 7167



### MEASURED TIME IN SECONDS UNTIL SLURRY FLOWS FROM ALL SPREADER OUTLETS

Test	Duration in seconds
Cattle manure, 4100 l/min	1.7
Cattle manure, 2924 l/min	2.3
Pig manure, 4101 l/min	1.3
Pig manure, 2928 l/min	1.5



Full test report

### RESULTS FOR TRANSVERSE DISTRIBUTION OF CATTLE AND PIG MANURE

Slurry type	PTO	Pump	Volume flow rate	Discharge rate	Coefficient of variation	Mean deviation	Rating
Cattle manure	740 rpm	370 rpm	4100 l/min	39.4 m <sup>3</sup> /ha at 5.2 km/h	3.2%	2.3%	++
Cattle manure	520 rpm	260 rpm	2924 l/min	18.3 m <sup>3</sup> /ha at 8.0 km/h	2.7%	2.2%	++
Pig manure	740 rpm	370 rpm	4101 l/min	39.4 m <sup>3</sup> /ha at 5.2 km/h	4.4%	3.4%	++
Pig manure	520 rpm	260 rpm	2928 l/min	18.3 m <sup>3</sup> /ha at 8.0 km/h	4.3%	3.0%	++

\* Rating based on mean deviation: ++ = ≤ 5%, + = ≤ 10%, o = ≤ 15%

## DLG Test Report 7228: FLIEGL SKATE 150



**FLIEGL SKATE 150 (15 METER)  
MIT FLIEGL SCHNECKENVERTEILERN**

✓ Funktion und Arbeitsqualität  
✓ Handhabung, Bedienung  
und Wartung

DLG-Prüfbericht 7228



### MEASURED TIME IN SECONDS UNTIL SLURRY FLOWS FROM ALL SPREADER OUTLETS

Test	Duration in seconds
Cattle manure, 5475 l/min	1.7
Cattle manure, 3871 l/min	2.6
Pig manure, 5196 l/min	1.4
Pig manure, 3640 l/min	2.1



Full test report

### RESULTS FOR TRANSVERSE DISTRIBUTION OF CATTLE AND PIG MANURE

Slurry type	PTO	Pump	Volume flow rate	Discharge rate	Coefficient of variation	Mean deviation	Rating
Cattle manure	560 rpm	560 rpm	5475 l/min	39.8 m <sup>3</sup> /ha at 5.5 km/h	3.9%	3.1%	++
Cattle manure	390 rpm	390 rpm	3871 l/min	19.4 m <sup>3</sup> /ha at 8.0 km/h	3.9%	3.0%	++
Pig manure	560 rpm	560 rpm	5196 l/min	40.0 m <sup>3</sup> /ha at 5.2 km/h	4.7%	3.8%	++
Pig manure	390 rpm	390 rpm	3640 l/min	18.2 m <sup>3</sup> /ha at 8.0 km/h	3.7%	3.0%	++

\* Rating based on mean deviation: ++ = ≤ 5%, + = ≤ 10%, o = ≤ 15%

# Optimum adaptation

Trap box opens mechanically or hydraulically



Extremely low overall height



Special inclined swivel joints



Autom. slope compensation for optimum ground adaptation

Extremely compact transport dimensions: transport width of 2600 mm at bottom and 2300 mm at top

Control block with oil filter



Angle sensors on left and right for uniform extension and retraction on slopes



Special folding mechanism prevents kinking of outlet hoses

Integrated overpressure protection



Even distribution quality with short outlet hoses



Coulter pressure 8 kg

Hose spacing 250 mm

# Accessories for »SKATE« trailing shoe spreader



1. Boom section control, mechanical or hydraulic
2. Control of hydraulic functions via load sensing
3. Upgrade for extremely high fibre content: shredding cutter for central mounting between tank and spreader (60 l oil capacity required). Powered directly via the tractor control unit
4. Only on SKATE 150 and 180: integrate impact protection – retraction reduces the working width
5. Holder for suction line (shown here in retracted state)
6. Hydraulic emptying of trap box
7. Feeler wheels for smoother operation at high travel speeds
8. Standard: T-piece for additional outlet, side deactivation required



9. Mechanical shut-off of individual hoses
10. Bypass control for gate valve side deactivation, hydraulic. Only possible with complete orders incl. pump tanks

## Fliegl TWIN – say goodbye to thick slurry trails

Fliegl TWIN is a V-shaped trailing shoe nozzle. It splits the slurry flow and thus halves the slurry quantity used for each slurry trail while simultaneously doubling the number of trails.

### Benefits

- Significantly lower feed contamination
- Greater efficiency during slurry application
- Increased substrate infiltration
- Can be retrofitted to existing Fliegl trailing shoe spreaders



Application with previous nozzle (unseparated slurry trail)



Application TWIN V-nozzle (split slurry trail)



Working light for illuminating the spreader



Additional spreading option with mounted baffle plate spreader



Supporting feet

# »SKATE SD« trailing shoe spreader



Shoe spacing of just 187,5 mm





		SKATE 120 SD	SKATE 150 SD
Working width	m	12	15
Number of outlets		64	80
Weight	kg	1350	1600
Transport width (top/bottom)	mm	2300/ 2600	2300/ 2600

Not compatible with TWIN nozzle!

- +** More slurry trails are applied closer together
- +** Reduces the amount of slurry applied by each hose
- +** Improved infiltration of the substrate
- +** Optimum line spacing for use in row crops

**REDUCED LINE SPACING MORE SLURRY TRAILS  
CAN ALSO BE USED IN TALLER CROPS**

# The perfect retrofit

Retrofit: note the drawbar load and permitted total weight of the tanker

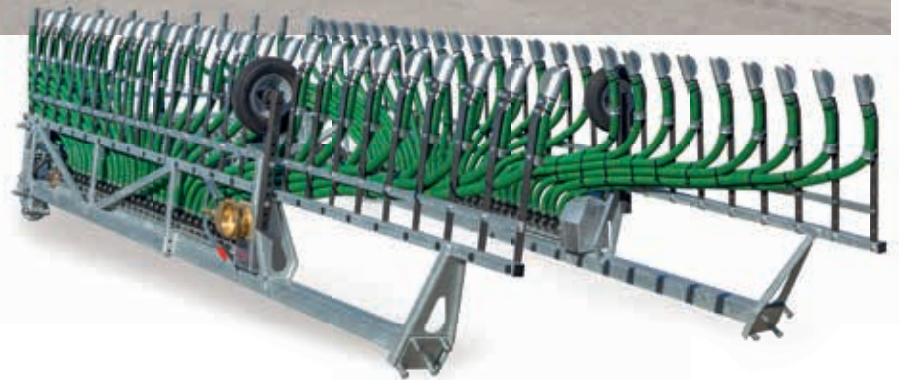

Also suitable for third-party GRP tanks

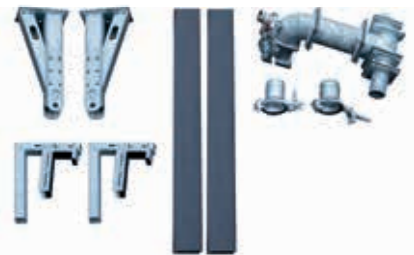

Scope of delivery: pre-assembled trailing shoe spreader, control panel and control block, H-frame, transport lock, T-piece with flexible hoses for the slurry feed

## Control via ISOBUS

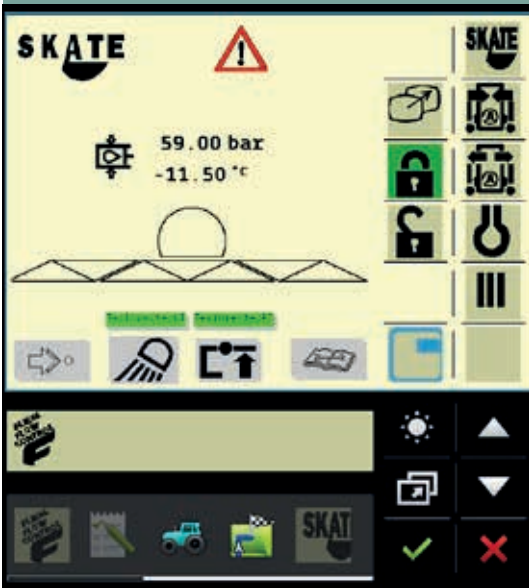

- User interface for Fliegl SKATE in combination with ISOBUS terminal
- Optional: Section Control

## "EASY" comfort control (standard equipment)

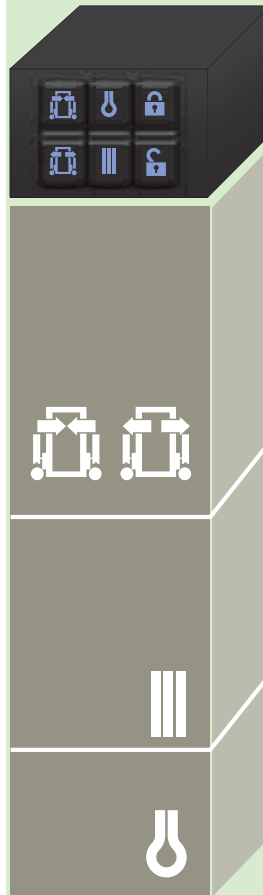

- Assists the driver and prevents operating errors
- The ergonomic control panel is backlit, while the plug connection enables easy disconnection from the cable so that the control panel can remain in the tractor.
- The folding of the spreader arms is monitored by sensors in all positions, which enables synchronised and dampened folding even on slopes.

### AUTOMATIC FOLDING

#### The spreader:

- Lifts out of the mechanical transport lock
- Folds the spreader arms back
- Lowers into working position

### AUTOMATIC SPREADING

- Discharge valve opens
- Spreading augers start working

### AUTOMATIC HEADLAND FUNCTION

- Spreading augers switch off
- Gate valve closes
- Spreader folds up



EASY comfort control panel



ISOBUS adapter cable enables quick changeovers

Using the ISOBUS adapter, the SKATE can be operated either with the standard EASY comfort control or via an ISOBUS terminal. Users can thus easily switch between older and newer tractors.

# »SNAKE« trailing shoe spreader

Variable use for slurry hose system  
or self-propelled transporters

+ Soil-friendly slurry application

+ Slurry application even in extremely wet weather  
and on marshy ground

+ Perfect system for steep inclines



## Ideal for your self-propelled slurry tanker

The Snake can be attached to any self-propelled slurry tanker in a matter of minutes, making this an exceptionally flexible system.

The spreader arms are folded together behind the towing machine. The size and shape of the container are irrelevant.

No mountings need to be attached to the tank and the spreader arms do not extend up to the cabin, which has a positive impact on all-round visibility.

Compact transport dimensions ensure very safe handling, particularly during road transport.





- Working widths of 8.50/12.00/15.00 m
- Extremely compact transport dimensions with 2.60 m width and max. 3.80 m height thanks to package folding mechanism.
- Equipped with the tried-and-tested Fliegl screw distributor
- Drip-stop function with hydraulic folding on headland

### Draw tube

- Hydraulically swivelling draw tube enables accurate guiding of the slurry hose and ensures comfortable turning on the headland
- Centred by two chains of equal length
- The Fliegl Flow Control digital flow meter helps to ensure an even slurry application

# »Garant« drag hose spreader

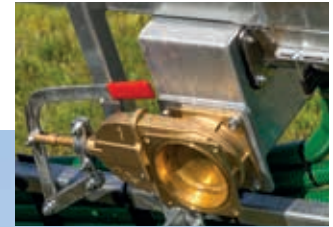

Trap box for foreign body separation



Screw distributor control unit



Pressure sequence valve

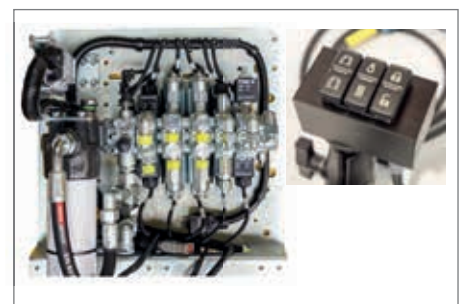

With optional »Easy« comfort control

## Working width of 6 to 18.00 m

- Slurry is deposited in strips directly on the soil surface
- With the tried-and-tested Fliegl screw distributor
- Foreign objects are automatically conveyed to the trap box
- Layout and structure of the frame and spreader arms as on the Fliegl SKATE
- Controlled via two tractor control units
- (1x for folding mechanism, 1x for screw distributor)
- Required oil capacity of max. 20 l
- Minimal power requirement

# »Vario-Disc« slurry injector

Patented system for perfect incorporation on grassland and farmland



Infinite adjustment of discs



Targeted application of slurry under the sward

## Working width of 3.00 m, 5.60 m and 7.15 m

- Use on farmland and greenland
- Can be mounted on virtually any slurry tank
- With the tried-and-tested Fliegl screw distributor
- Fully galvanised frame
- Maintenance-friendly
- Hydraulic folding mechanism
- Adjustable support wheels
- Robust taper roller bearings
- Disc diameter 530 mm

## »Maulwurf« compact disc harrow

Easy-pull soil cultivation and targeted incorporation of slurry in a single operation



### Working width of 3.00 m, 5.70 m and 6.90 m

- With the tried-and-tested Fliegl screw distributor
- Thanks to the large coulters, the subsoil is turned over and the slurry completely covered in a single operation
- Hydraulic folding mechanism (for 4.50 m and 6.00 m working widths)
- Large adjustable support wheels
- Robust taper roller bearings
- Disc diameter: 510 mm



# »GUG Profi« slurry cultivator

Powerful soil cultivation and targeted incorporation of slurry in a single operation

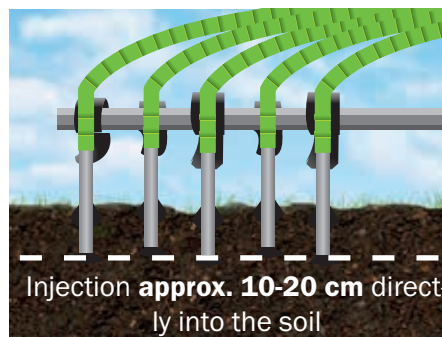

**GUG working width: 3.00 m | GUG Profi working width: 4.50 m and 6.00 m**

- For uncultivated farmland
- Robust cultivator tines for the toughest applications
- Replaceable dual-heart blades
- Can be mounted on virtually any slurry tank
- With the tried-and-tested Fliegl screw distributor
- Fully galvanised frame
- Hydraulic folding mechanism (for 4.50 m and 6.00 m working widths)
- Maintenance-friendly
- Easy to operate
- Height-adjustable support wheels

# Other spreading systems

Observe the national fertiliser ordinance



Wide spreader



Combi spreader, folding



Hydraulic pendulum spreader with working width from 12 to 18 m.



More information on baffle plate spreaders



Be it baffle plate, pendulum or bar spreaders: in addition to ground-level injection systems, we also offer classic spreading systems such as baffle plate, wide and combi spreaders.



Double pendulum spreader, hydraulic

Pendulum spreader for coarse-droplet application





ISOBUS APPLICATIONS  
EASY COMPATIBILITY





# Fliegl Slurry Tanker

Perfection in slurry spreading



**Fliegl Slurry Tanker (FST) is a control system that enables convenient control of the various functions of a slurry tanker via an ISOBUS display.**

- Facilitates slurry application
- Greater ease of use and enhanced safety during fertilisation
- The control system uses the existing ISOBUS display, thus eliminating the need for an additional control panel in the tractor.
- Compatible with any ISOBUS display (AEF certification)
- Load-sensing-enabled as standard – i.e. the hydraulic functions are always supplied only with the quantity of oil actually required; this not only reduces oil heating but also fuel consumption.



### Three different modes

Separate modes are provided for road, farm and field operation. This is because only specific functions are available in each mode. In farm mode, for example, the three-way valve at the rear cannot be operated since this mode is intended for filling operations. Malfunctions or operator errors are thus excluded. Field mode consists of one or more pages, depending on the number of tank functions.



User interface for **FST farm mode**

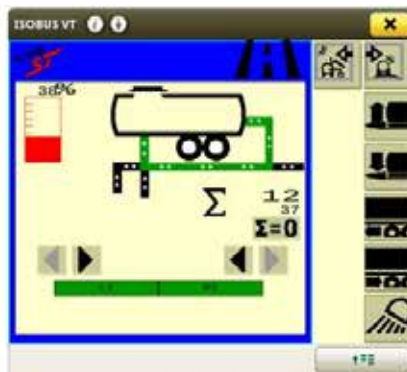

User interface for **FST road mode**

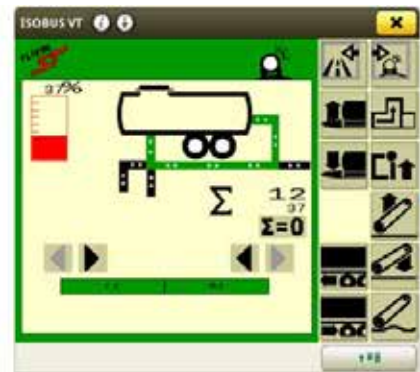

User interface for **FST field mode**

The Fliegl Slurry Tanker principle combines two crucial advantages: **clarity** and **safety during operation**. At any given time, only the applications relevant to the current mode can be used. For example, it is not possible to open the slurry gate valve in road mode since only the drawbar suspension and hydr. axle adjustment functions can be operated in this mode.



Hydraulic control block



ISOBUS job computer

# Precision: Fliegl Flow Control

Digital flow rate measurement.



## Basic FFC version with digital flow meter



The flow rate during discharge is measured inductively by means of the Krohne Optiflux 2300 digital flow meter.



FFC control cabinet with integrated job computer and ISOBUS interface



FFC user interface on the ISOBUS display

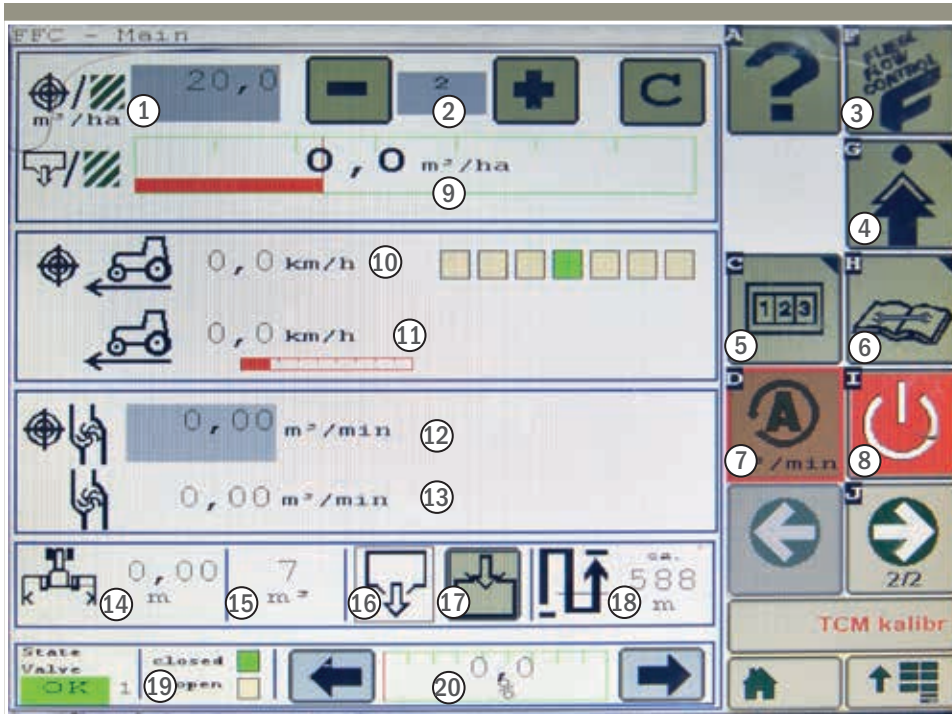

1. Entry of discharge rate per ha
2. Increase or reduce discharge rate
3. Main page
4. Settings
5. "Totals": Information on total amount of slurry spread, duration, etc.
6. Diagnostics
7. Switch from automatic to manual operation
8. On/Off button
9. Current discharge rate per ha
10. Target speed
11. Current speed
12. Target flow rate
13. Current flow rate
14. Current working width
15. Total slurry discharged
16. Emptying signal
17. Filling signal
18. Range display
19. Setting of three-way valve
20. Display of three-way valve position





## FFC/DMR pump tank + three-way valve

With the optional flow rate control (DMR), the flow rate (per minute) is automatically adapted to the travel speed via an electric cylinder attached to the three-way valve. Particularly on sloping terrain, frequent adjustments must be made by the driver. With this system, the required discharge rate (per hectare) is maintained regardless of the travel speed.



## FFC/DMR vacuum tank + discharge accelerator

The flow rate control for vacuum tanks is implemented by means of a hydr. controlled discharge accelerator at the rear of the tank. The speed of the accelerator is adjusted via a stepper motor valve on the control block. Even when the travel speed is changed, the required discharge rate is maintained by adapting the revolutions on the discharge accelerator accordingly.

# TIA

Tractor Implement  
Automation

## FFC/AMR

Spreading rate control (AMR) by means of automatic adaptation of the travel speed on the tractor.

With the spreading rate control, the slurry volume is controlled by means of active intervention in the tractor's travel speed based on the flow rate measurement on the tank.

Tractor Implement Automation (TIA) is only available for infinitely variable tractors featuring the ISOBUS class III system (implemented by the tractor manufacturer) and is only recommended for **very level surfaces**.



# It's what's inside that counts!

## Nutrient-based spreading with **Manure Sensing**

As slurry is often very heterogeneous, you never actually know the nutrient content that is being spread per hectare at a given time. With Manure Sensing, the nutrient content (N, NH<sub>4</sub>, P, K) of the slurry is measured in real time. If you know the nutrient concentration of the slurry in the tank, you can adapt the discharge rate to the nutrient requirement for the relevant surface. In combination with **Fliegl Flow Control**, the discharge rate can be adjusted in kg N/ha. This allows you to optimise the nutrient balance, make the best use of the nutrients in your slurry and maximise your potential yield. This makes managing the nutrient balance much simpler since, similarly to mineral fertilisation, you know exactly how many kilogrammes of each nutrient have been spread per hectare. Moreover, if you make optimum use of your slurry with Manure Sensing, you can usually reduce the amount of mineral fertilisers used.



Gold medal for John Deere

Product: Connected Nutrient Management

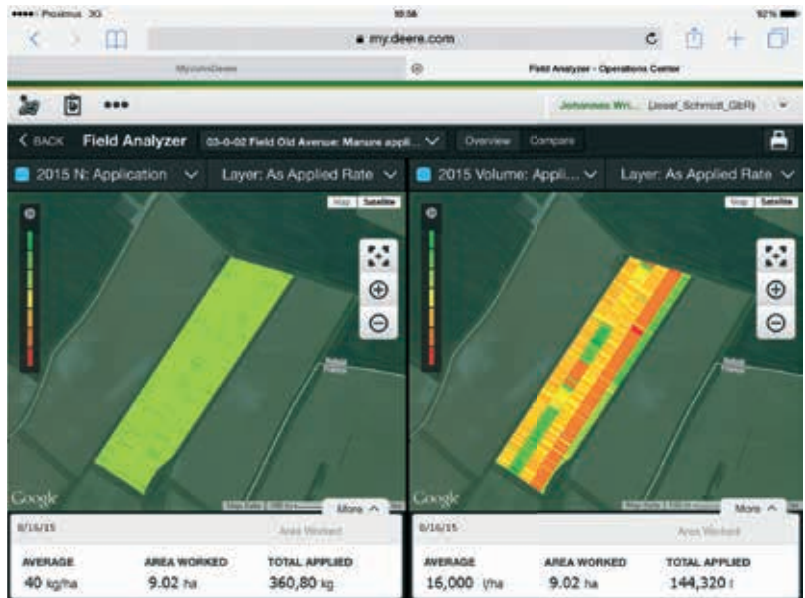

Left: slurry spread based on kg N/ha  
 → even N distribution on the field

Right: slurry distribution in l/ha  
 → uneven N-distribution inside a tank

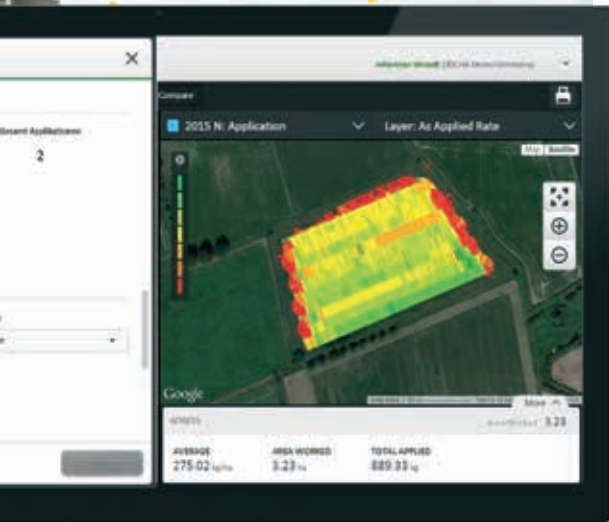

In this example, spreading was regulated according to the nutrient potash; the N distribution can be seen on the right of the image.



John Deere HarvestLab 3000 uses near-infrared (NIR) spectroscopy to determine the various constituents of slurry, harvested crops or silage in less than a second.

- Real-time measurement of N, P, K, NH4, dry mass and volume, directly before the applicator
- Precise, requirement-based spreading of organic and mineral N and P fertilisers
- Automatic tractor speed adjustment (only for infinitely variable John Deere tractors with ISOBUS class 3)
- Documentation:
  - Volume applied
  - Nutrients applied (total per field and specific subareas)
- Utilises the entire nutrient potential of the slurry while also complying with statutory regulations. The advantages are clear: Yields and product quality are maximised while costs for mineral fertilisers are reduced.
- Maximum control range and rapid response based on speed variation and – in the second instance – adjustment of the flow rate via **Fliegl Flow Control**
- Combines the expertise and technologies of all innovation partners and thus enables nutrient application in accordance with the national fertiliser ordinance.
- Maximised yield potential



# Fliegl Nutrient Measure Station

Active on-site measurement of nutrients in real time

## High flexibility

- 6" and 8" versions available
- Straightforward intake via suction nozzle
- With integrated flow meter (records the total amount of nutrients)
- Tried-and-tested John Deere HarvestLab sensor for measuring digestate, cattle and pig manure (expandable for measurements at the shredder)
- Measurement of dry mass, total nitrogen (N), ammonium nitrogen (NH<sub>4</sub>-N), phosphorus (P<sub>2</sub>O<sub>5</sub>), potassium (K<sub>2</sub>O), volume, mass
- Software enables creation of customers and vehicles and generation of measurement reports
- Data transfer via Wi-Fi router
- Convenient transport via forklift pockets, three-point hitch or Euronorm mounting

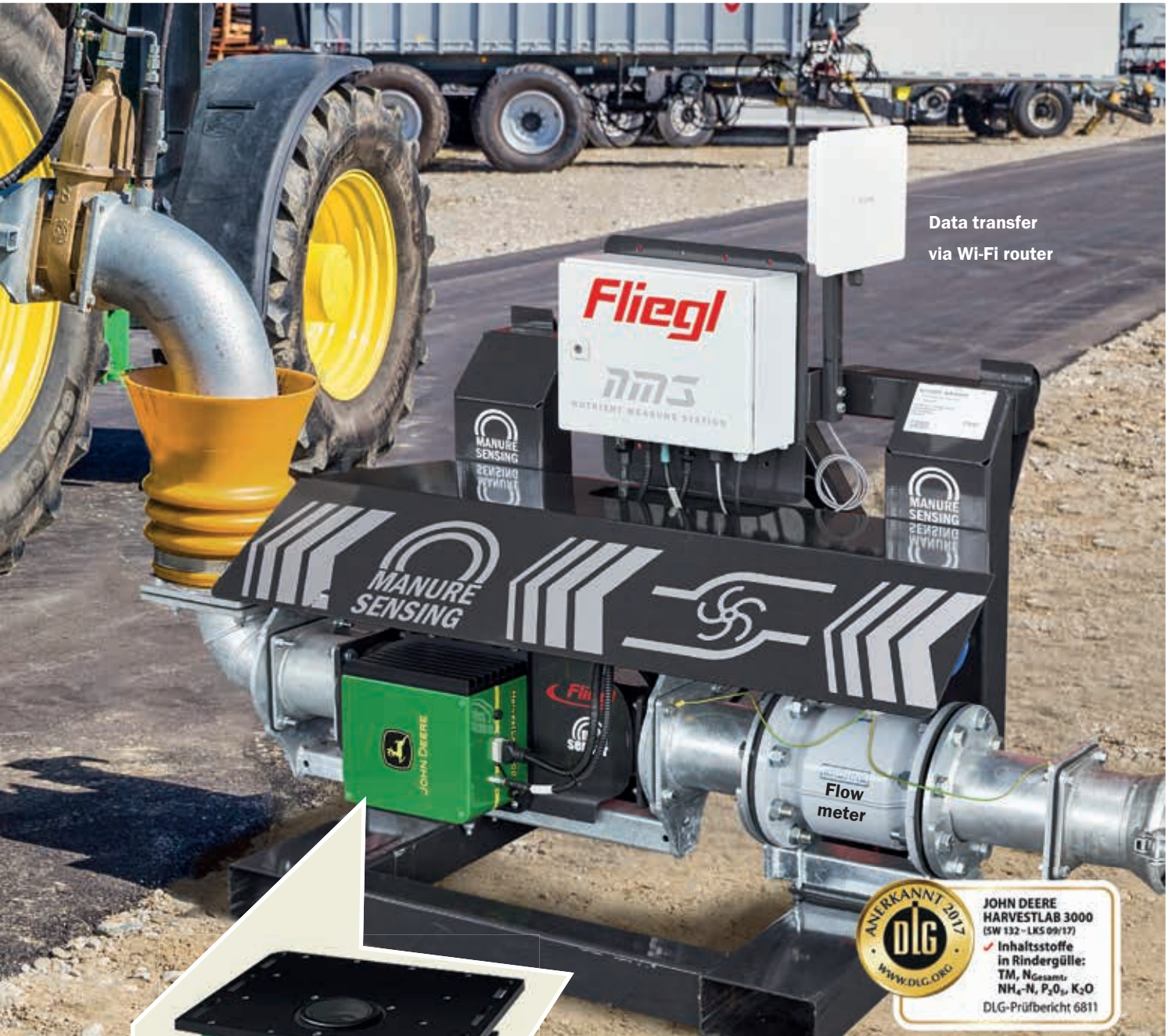

Data transfer  
via Wi-Fi router



**JOHN DEERE  
HARVESTLAB 3000**  
(SW 132 - LKS 09/17)  
✓ Inhaltsstoffe  
in Rindergülle:  
TM, N<sub>Gesamt</sub>,  
NH<sub>4</sub>-N, P<sub>2</sub>O<sub>5</sub>, K<sub>2</sub>O  
DLG-Prüfbericht 6811



**JOHN DEERE  
HARVESTLAB 3000**  
(SW 132 - LKS 04/18)  
✓ Inhaltsstoffe  
in Schweinegülle:  
TM, N<sub>Gesamt</sub>, P<sub>2</sub>O<sub>5</sub>  
DLG-Prüfbericht 6886



**JOHN DEERE  
HARVESTLAB 3000**  
(SW 132 - LKS 08/17)  
✓ Inhaltsstoffe in  
flüssigem Gärrest:  
TM, N<sub>Gesamt</sub>  
DLG-Prüfbericht 6809

### John Deere HarvestLab 3000

HarvestLab™ 3000 uses near-infrared (NIR) spectroscopy to determine the various constituents of harvested crops, silage or slurry in less than a second. The new HarvestLab™ 3000 uses state-of-the-art technology and is based on millions of hours of farming experience. Thanks to its 12% wider wavelength spectrum, the sensor achieves greater accuracy and provides more than 4000 measurement points per second. You do not simply receive the result of a random sample check but are instead provided with statistically reliable data in real time.







**Fliegl Agrartechnik GmbH**

Bürgermeister-Boch-Str. 1 | 84453 Mühldorf a. Inn | Germany

Tel.: +49 (0) 86 31 307-0 | Fax: +49 (0) 86 31 307-550 | E-mail: [info@fliegl.com](mailto:info@fliegl.com)

Dimensions, weights, and technical data are subject to change.

Some images show special equipment.

Full catalogue 04-2023

